



REPUBLIKA NG PILIPINAS
KAGAWARAN NG KATARUNGAN
PANGASIWAAN SA PATALAAN NG LUPAIN
(LAND REGISTRATION AUTHORITY)
East Avenue cor. NIA Road, Quezon City
Website: www.lra.gov.ph

May 24, 2023

REQUEST FOR QUOTATION

The LAND REGISTRATION AUTHORITY (LRA) is inviting all interested Contractors to submit a Quotation for the **Procurement of the Replacement of Broken Glass on Various Offices at the Central Office, LRA Building, Quezon City** subject to the submission of the following requirements:

1. Certified true copy of current Mayor's permit;
2. Phil GEPS registration certificate;
3. Certified true copy of PCAB License;
4. Income/Business Tax Return;
5. Omnibus Sworn Statement (Form "C");
6. Quotation (Form "A");
7. Affidavit of Site Inspection; and
8. List of completed and on-going Contracts (Form "B")

Completion of the works is required within Thirty (30) working days from commencement date.

A complete set of Scope of Work, Form B, Form A, Form C and Shop Drawing may be purchased by interested contractors at the BAC Infrastructure Secretariat Office, 5th floor, LRA Building corner NIA Road, Diliman, Quezon City, upon payment of a non-refundable fee in the amount of PESOS: FIVE HUNDRED (PHP 500.00). Deadline for the submission of sealed proposals together with the complete documentary requirements is on May 30, 2023, 4:00 p.m. at the BAC Secretariat Office, 5th floor, LRA building, East Avenue corner NIA Road, Quezon City. Any submission of bid other than to the LRA-BAC Secretariat Office shall not be entertained/admitted.

The Approved Budget for the project is PESOS: **ONE HUNDRED NINETY-THREE THOUSAND SEVEN HUNDRED THIRTY-SIX and 00/100 (P 193,736.00).**

IMPORTANT TERMS and CONDITIONS

1. All quotations submitted to this Authority are considered as offer. In the event that quotation is accepted, a Work Order shall be placed with the contractor offering the Single/Lowest complying and responsive bid, therefore, the most advantageous terms to this Authority;
2. Work is subject to inspection and acceptance. Payment shall be in accordance with the usual budgeting, accounting and auditing requirements; and
3. This Authority reserves the right to reject any or all bids or offers and may only accept such offer that it may consider most economical and most advantageous to the Government.

ATTY. TRISTAN E. DE GUZMAN
Chairman
Bids and Awards Committee on Infrastructure

GLORIETA P. LACAMBRA
Actg. Chief, General Services Div.

Quotation Form (Form "A")

PROJECT : Replacement of Broken Glass on Various Offices at the Central Office,
 LRA Building, Quezon City
 LOCATION : LRA Building, Quezon City
 SUBJECT : BILL OF QUANTITIES

ITEM	DESCRIPTION	UNIT	QUANTITY	UNIT COST	AMOUNT
I.	SITE WORKS				
1.00	Mobilization/De-mobilization/Temporary facilities	lot	1.00		
	Sub - Total				
II.	GLASS				
1.00	Supply and Installation of ¼ Bronze Glass Ordinary (Assorted Size) Including dismantling of existing Broken Glass	set/s	1.00		
	Sub - Total				
III.	All other items not included herein but necessary to complete the project, please specify				
1.00	Misc. and Consumables	lot/s	1.00		
	Sub - Total				
TOTAL BID COST (Inclusive of Taxes)					

BID AMOUNT IN WORDS

Submitted by:

Name of Company

By:

Name & Signature of Authorized Representative

Date

PROJECT : Replacement of Broken Glass on Various Offices at the Central Office,
LRA Building, Quezon City
LOCATION : LRA Building, Quezon City
SUBJECT : SCOPE OF WORKS

SCOPE OF WORKS AND SPECIFICATION

1. Mobilization/De-Mobilization of personnel, materials, equipments, provision of temporary facilities and utilities and upon completion cleaning of the work area and disposal of waste materials and debris as to leave the premises in perfect condition, accepted by LRA.
2. Dismantling of Existing broken window glass.
3. Supply and installation of new ¼ Bronze Glass with different measurement (see attached drawings). This is to include all necessary materials for the completion of the project.
4. All items mentioned above subject for inspection and approval of LRA before installation.
5. Site visit is required.

WORK DURATION: Three (3) Working days

(Form "B")

PROJECT : Replacement of Broken Glass on Various Offices at the Central Office, LRA Building, Quezon City
 LOCATION : Various Offices at the Central Office, LRA Building, Quezon City
 SUBJECT : LIST OF COMPLETED AND ON-GOING CONTRACTS

Name of Contract	Date of Contract	Contract Duration	Owner's name and address	Nature of Work	Total Contract Value	Date of Completion of Estimated Completion date	Value of Outstanding Works, If applicable	Remarks

Submitted by:

 (Name and Signature of Bidder)

 (Company)

 (Date)

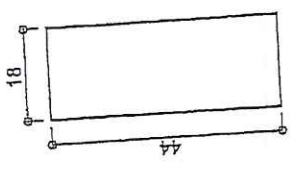
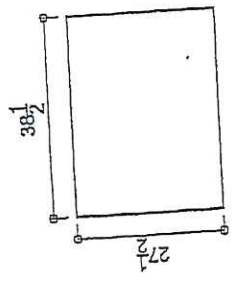
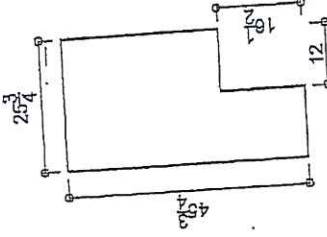
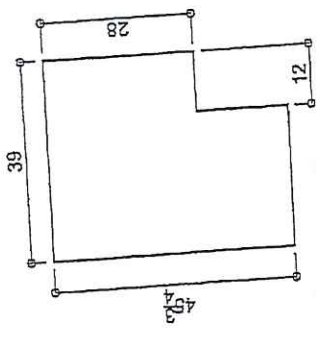
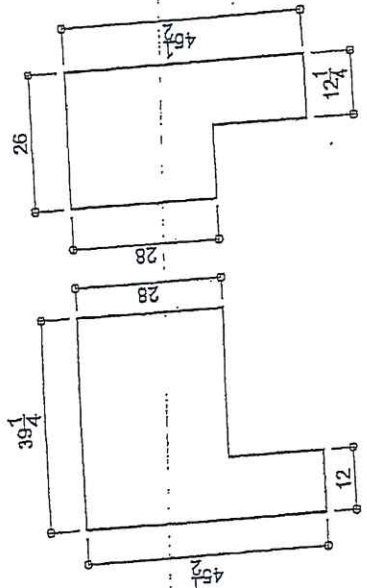
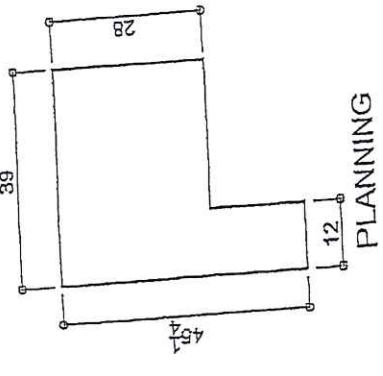
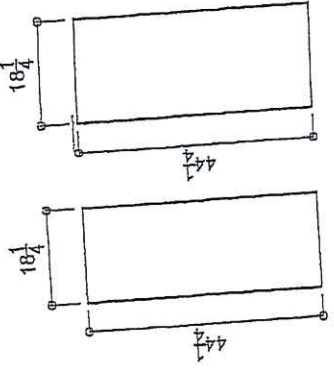
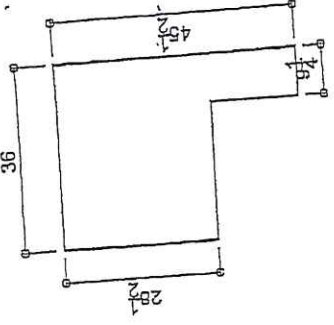

DOCKET DIVISION

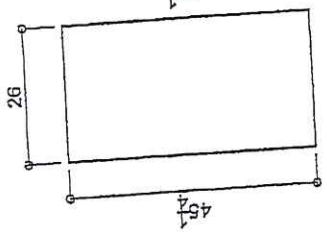
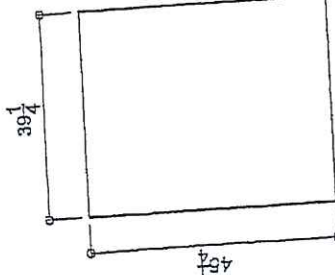
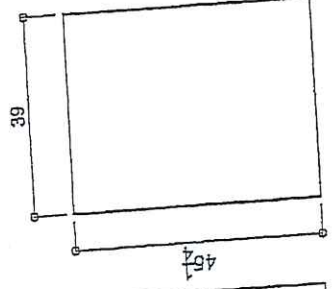

LAND PROJECTION SECTION

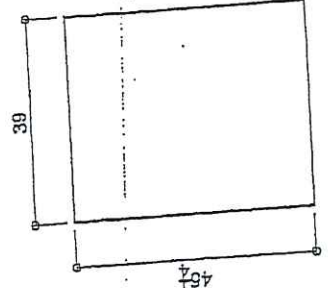
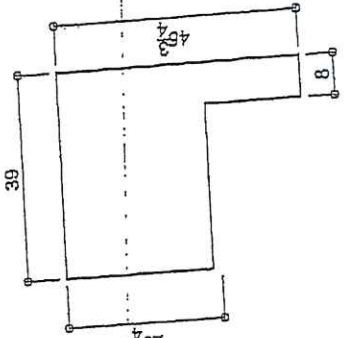

CADASTRAL SECTION

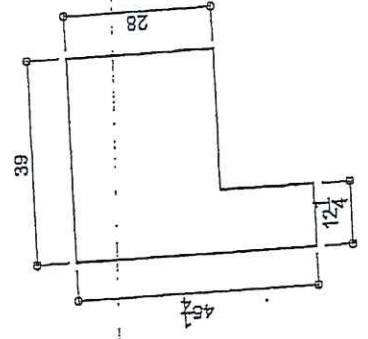
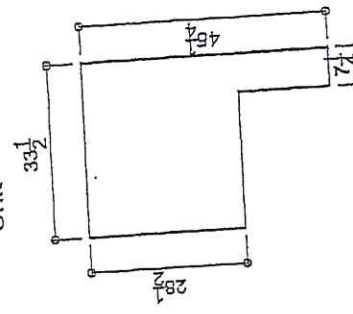

SUB

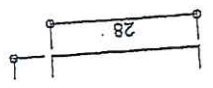
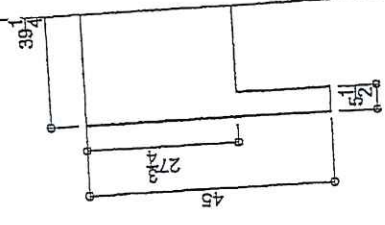

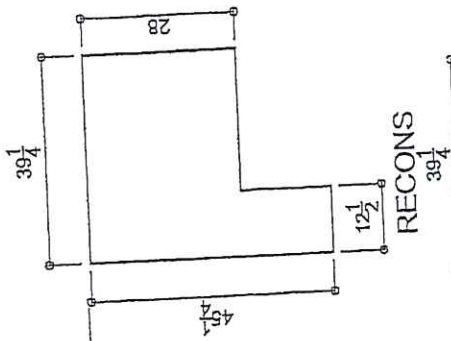
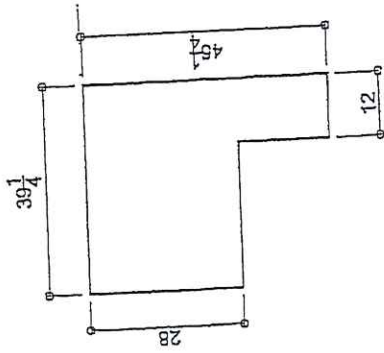
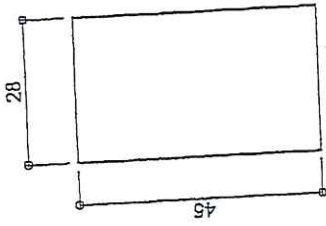
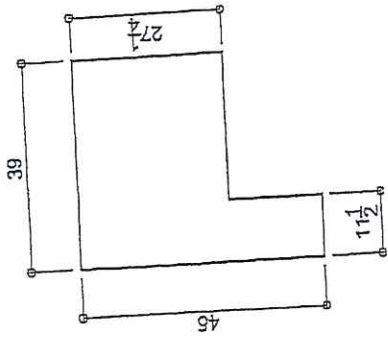

IID

COA

RECONS

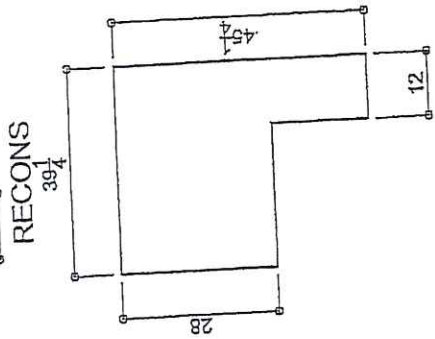
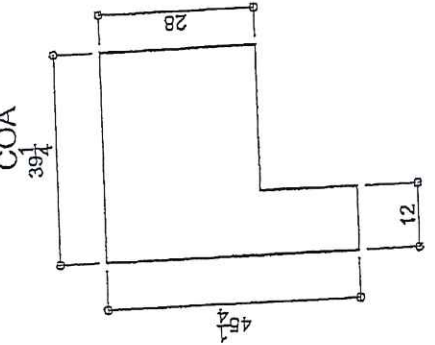
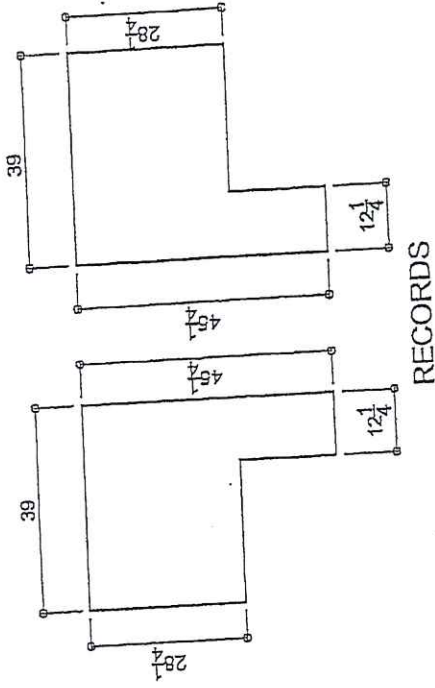

RECORDS

CLERK

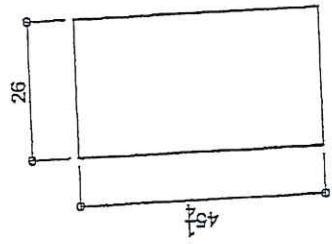
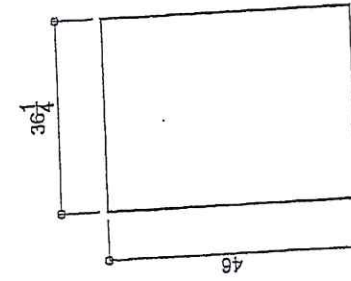
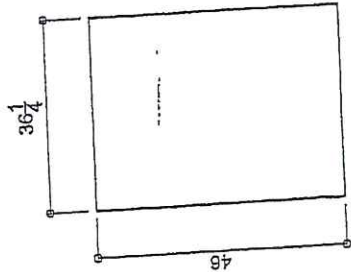

EXIT

HRDD

REPUBLIC OF THE PHILIPPINES
CITY/MUNICIPALITY OF _____ S.S.

AFFIDAVIT

I, [Name of affiant], of legal age, [Civil Status], [Nationality], and residing at [Address of Affiant], after having been duly sworn in accordance with law, do hereby depose and state that:

1. Select one, delete the other:

If a sole proprietorship: I am the sole proprietor of [Name of Bidder] with office address at [address of Bidder];

If a partnership, corporation, cooperative, or joint venture: I am the duly notarized and designated representative of [Name of Bidder] with office address at [address of Bidder];

2. Select one, delete the other:

If a sole proprietorship: As the owner and sole proprietor of [Name of Bidder], I have full power and authority to do, execute and perform any and all acts necessary to represent it in the bidding for [Name of the Project] of the [Name of the Procuring Entity];

If a partnership, corporation, cooperative, or joint venture: I am granted full power and authority to do, execute and perform any and all acts necessary to and/or to represent the [Name of Bidder] in the bidding as shown in the attached [state title of attached document showing proof of authorization (e.g., duly notarized Secretary's Certificate issued by the corporation or the member of the joint venture)];

3. [Name of Bidder] is not "blacklisted" or barred from bidding by the Government of the Philippines or any of its agencies, offices, corporations, or Local Government Units, foreign government /foreign or international financing institution whose blacklisting rules have been recognized by the Government Procurement Policy Board;

4. Each of the documents submitted in satisfaction of the bidding requirements is an authentic copy of the original, complete, and all statements and information provided therein are true and correct;

5. [Name of Bidder] is authorizing the Head of the Procuring Entity or its duly authorized representative (s) to verify all the documents submitted;

6. Select one, delete the rest:

If a sole proprietorship: I am not related to the Head of the Procuring Entity, members of the Bids and Awards Committee (BAC), the Technical Working Group, and the BAC Secretariat, the head of the Project Management Office or the end-user unit, and the project consultants by consanguinity or affinity up to the third civil degree;

If a partnership or cooperative: None of the officers and members of [Name of Bidder] is related to the Head of the Procuring Entity, members of the Bids and Awards Committee (BAC), the Technical Working Group, and the BAC Secretariat, the head of the Project Management Office or the end-user unit, and the project consultants by consanguinity or affinity up to the third civil degree;

If a corporation or joint venture: None of the officers, directors and controlling stockholders of [Name of Bidder] is related to the Head of the Procuring Entity, members of the Bids and Awards Committee (BAC), the Technical Working Group, and the BAC Secretariat, the head of the Project Management Office or the end-user unit and the project consultants by consanguinity or affinity up to the third civil degree;

7. [Name of Bidder] complies with existing labor laws and standards, and
8. [Name of Bidder] is aware of and has undertaken the following responsibilities as a Bidder:
 - a) Carefully examine all of the Bidding Documents;
 - b) Acknowledge all conditions, local or otherwise, affecting the implementation of the contract;
 - c) Made an estimate of the facilities available and needed for the contract to be bid. If any, and
 - d) Inquire or secure Supplemental /Bid Bulletin(s) issued for the [Name of the Project]

IN WITNESS WHEREOF, I have heretunto set my hand this ____ day of _____, 202~~0~~ at _____, Philippines.

Bidder's Representative / Authorized Signatory

SUBSCRIBED AND SWORN to before me this ____ day of _____, 2021, exhibiting to me his CTC No. _____, issued on _____, issued at _____

Notary Public

Doc. No. _____;
Page No. _____;
Book No. _____;
Series of 202~~3~~